

# HUS115IN

## Husky Integrated Bar Fridge Freezer



### Specifications

GTIN	9351116005610
Designed to Suit	Inside
Function	Fridge/ Freezer
Gross Total Capacity (Litres)	Fridge 115lt / Freezer 97.6lt
Food Safe	Yes
Colour	White
Door Type	1 x RH Hinged Door
Reversible Door	Yes
Handle	N/A
Shelves	1
Feet	2 (front adjustable)
Back of unit material	Metal
Exterior Colour	White
Interior Colour	White
Interior Light	LED Bulb 15W
Door Lock	No
Temperature Control	Mechanical
Temperature Range (°C) Min	-18
Temperature Range (°C) Max	10
Cooling Type	Static
Defrost	Automatic
Refrigerant	R600a
Energy Star Rating	3.5
Annual Energy Consumption	165 kWh/Year
Voltage Frequency	220-240 V at 50Hz
Noise Level (Dba)	39
Gross Weight (Kg)	29.5
Internal Fridge Dimensions (mm)	H 540 x W 520 x D 460 (approx)
Internal Freezer Dimensions (mm)	H 140 x W 440 x D 285 (approx)
External Product Dimensions (mm)	H 812-818 x W 595 x D 548
Packaging Dimensions (mm)	H 820-890 x W 608 x D 550
Required Ventilation (mm)	150 mm at the top of the unit
Country of Origin	Turkey
Warranty	3 Years



#### Integrated Design

Integrated are designed to blend in with cabinetry and other kitchen fixtures, creating a seamless, built-in appearance.



#### Mechanical Temperature Control

This fridge comes with a temperature control dial inside the fridge.



#### Storage

This unit comes with a large draws, including store on the inside of the door. This fridge features a tempered glass shelf.



#### Food Safe

A food-safe fridge or freezer is designed to ensure that food is stored at the correct temperatures to prevent spoilage and contamination, while also adhering to safety standards for materials and operation.



#### Reversible Door Hinge

Reversible hinges can be installed to allow the door to swing out either left or right, depending on the needs of the space or the user's preference.



#### 3 Year Warranty

Three-year product warranty covering labour and parts ensures peace of mind

# Husky Integrated Bar Fridge Freezer Cabinet Dimensions

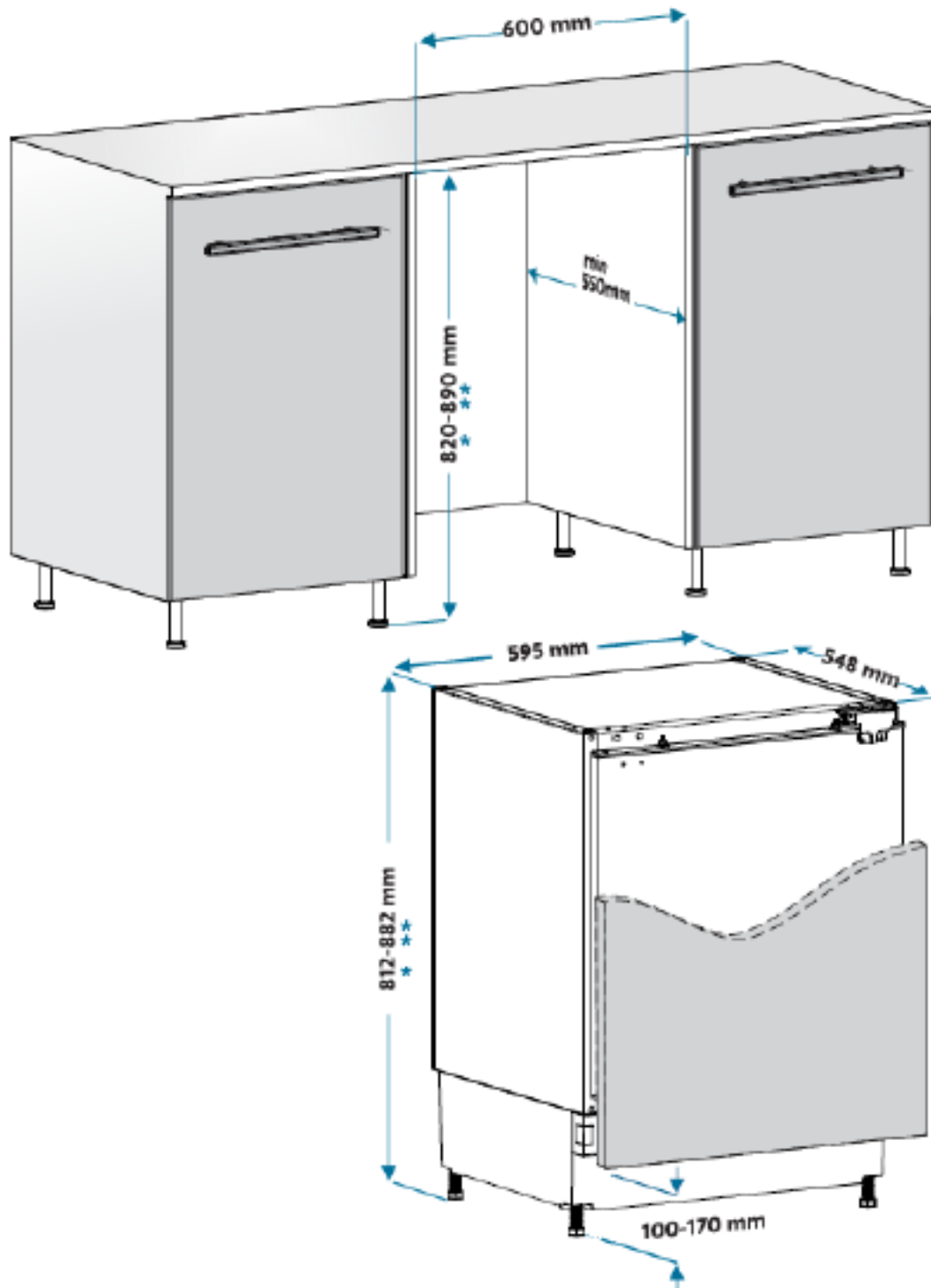

Please note: All measurements are approximate and subject to slight variation.  
Please verify dimensions with actual product before planning or installation.